

E450AJ

ELECTRIC BOOM



II 3G IIB T4 Gc



ATEX EQUIPMENT



KEY SPECS

Platform Height
13.72-m

Up and Over Reach
7.7-m

Horizontal Outreach
7.24-m

Platform Capacity
227-kg

KEY FEATURES

- Maximum maneuverability by moving over uneven surfaces with Automatic Traction Control.
- Produce zero emissions, 100% environmentally friendly.
- Achieve optimum productivity with longer duty cycles.
- Enhanced up and over access with jib.

STANDARD SPECIFICATIONS

Performance

Platform Height	13.72-m
Horizontal Outreach	7.24-m
Up and Over Clearance	7.7-m
Swing	360 Degrees Non-Continuous
Platform Capacity	227-kg
Platform Rotator	180 Degrees Hydraulic
Jib Range of Articulation (Vertical)	141 Degrees (+86, -55)
Weight*	6,532-kg
Ground Bearing Pressure	7.6 kg/cm ²
Max Drive Speed	7.2 km/h
Gradeability	30%
Turning Radius Inside (2WS/4WS)	0.61-m
Turning Radius Outside (2WS/4WS)	3.15-m

Power Source

Electrical System	48V DC
Batteries	8 x 6V, 375 amp-hr
Drive Motors	Dual Electric Traction

Tires

Standard	In 240/55D 17.5 Foam-Filled Non-marking
----------	---

Hydraulic System

Capacity	15.14 L
Motor/Pump	Permanent Magnet Motor/Gear Pump

E450AJ

ELECTRIC BOOM



II 3G IIB T4 Gc



ATEX EQUIPMENT

DIMENSIONS

All dimensions are approximate

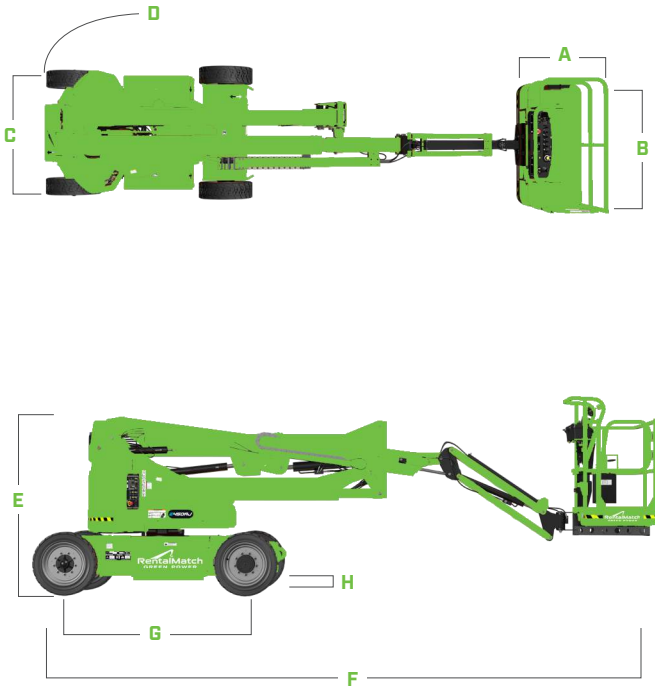

A. Platform Width	30-in / 76-cm
B. Platform Length	60-in / 1.52-m
C. Machine Width	5-ft 9-in / 1.75-m
D. Tailswing	0-in / 0-cm
E. Machine Height	6-ft 7-in / 2.01-m
F. Machine Length	21-ft 2-in / 6.45-m
G. Wheelbase	6-ft 7-in / 2.01-m
H. Ground Clearance	8-in / 20-cm

REACH DIAGRAM

