



## STANDARD SPECIFICATIONS

### Performance

Platform Height	18.29-m
Horizontal Outreach	13.11-m
Swing	400 Degrees Non-Continuous
Platform Capacity	230-kg
Platform Rotator	180 Degrees Hydraulic
Jib Range of Rotation	180 Degrees Hydraulic
Jib Range of Articulation (Vertical)	145 Degrees (+89, -56)
Weight	7,705-kg
Ground Bearing Pressure	3.9 kg/cm <sup>2</sup>
Max Drive Speed	4.8 km/h
Gradeability	30%
Turning Radius Inside (2WS/4WS)	1.23-m
Turning Radius Outside (2WS/4WS)	4.65-m

### Power Source

Electrical System	48V DC
Batteries	8 x 6V, 415 amp-hr
Drive Motors	Dual Electric Traction - Brushless AC

### Tires

Standard	36/14 LL-22.5 Foam-Filled Non-marking
----------	---------------------------------------

### Hydraulic System

Capacity	56.78 L
Motor/Pump	Series Wound Motor/Gear Pump

### KEY SPECS

**Platform Height**  
18.29-m

**Platform Capacity**  
230-kg

**Horizontal Outreach**  
13.11-m

### KEY FEATURES

- Maximum maneuverability by moving over uneven surfaces with Automatic Traction Control.
- Produce zero emissions, 100% environmentally friendly.
- Achieve optimum productivity with longer duty cycles.

## DIMENSIONS

All dimensions are approximate

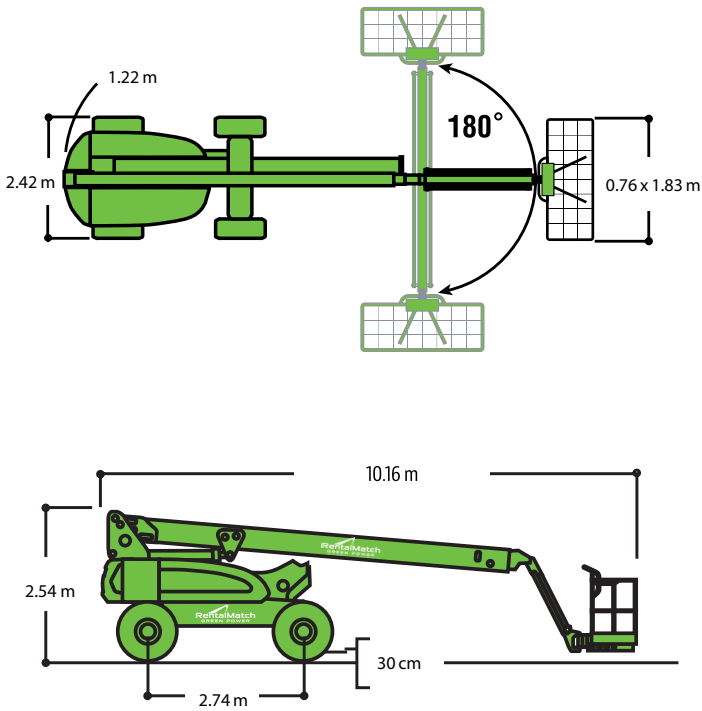

## REACH DIAGRAM

